

PVL6436AS, PVL6438NS, PUL6438S Programmable, VAV/Unitary Controllers

INSTALLATION INSTRUCTIONS

PRODUCT DESCRIPTION

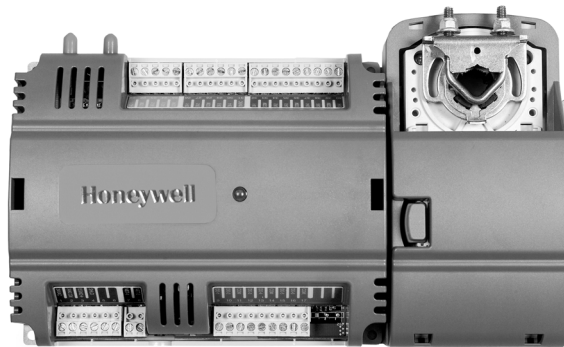

The PVL6436AS, PVL6438NS, and PUL6438S controllers are part of the Excel 10 product line family. The three controllers are Free Topology Transceiver (FTT) LONMARK®-compliant devices designed to control HVAC equipment. These controllers provide many options and advanced system features that allow state-of-the-art commercial building control. Each controller is programmable and configurable through software.

These controllers are for use in VAV (Variable Air Volume) and Unitary HVAC control applications. Each controller contains a host micro controller to run the main HVAC application and a second micro controller for LONWORKS® network communications. Each controller has flexible, universal inputs for external sensors, digital inputs, and a combination of analog and digital Triac outputs. The three models are described in Table 1. The photo to the left is the model PVL6436AS, which includes the actuator.

Table 1. Controller Configurations.

Controller Model	Programmable Type	Universal Inputs (UI)	Digital Inputs (DI)	Analog Outputs (AO)	Digital Outputs (DO)	Velocity Pressure Sensor (Microbridge)	Series 60 Floating Actuator
PVL6436AS	VAV	6	4	3	6	YES	YES
PVL6438NS	VAV	6	4	3	8	YES	NO
PUL6438S	Unitary	6	4	3	8	NO	NO

Each controller communicates via the 78 kbps Echelon® LONWORKS® Network, using the FTT-10A LONWORKS® interface, and is LONMARK® compliant.

Controllers are field-mountable to either a panel or a DIN rail.



SPECIFICATIONS

General Specifications

Rated Voltage: 20-30 Vac; 50/60 Hz

Power Consumption:

100 VA for controller and all connected loads (including the actuator on model PVL6436AS)

Controller Only Load: 20 VA maximum; models PVL6438NS and PUL6438S

Controller and Actuator Load: 21 VA maximum; model PVL6436AS

External Sensors Power Output: 20 Vdc $\pm 10\%$ @ 75 mA maximum

VAV Operating & Storage Temperature Ambient Rating (models PVL6436AS and PVL6438NS):

Minimum 32° F (0° C); Maximum 122° F (50° C)

Unitary Operating & Storage Temperature Ambient Rating (model PUL6438S):

Minimum -40° F (-40° C); Maximum 150° F (65.5° C)

Relative Humidity: 5% to 95% non-condensing

LED: provides status for normal operation, controller down-load process, alarms, manual mode, and error conditions

Velocity Pressure Sensor (models PVL6436AS and PVL6438NS only)

Operating Range: 0 to 1.5 in. H₂O (0 to 374 Pa)

Accuracy: $\pm 2\%$ of full scale at 32 to 122° F (0 to 50° C); $\pm 1\%$ of full scale at null pressure

Series 60 Floating Actuator (model PVL6436AS only)

Rotation Stroke: 95° \pm 3° for CW or CCW opening dampers

Torque Rating: 44 lb-in. (5 Nm)

Run Time for 90° rotation: 90 seconds at 60 Hz

Operating Temperature: -4 to 140° F (-20 to 60° C)

Real Time Clock

Operating Range: 24 hour, 365 day, multi-year calendar including day of week and configuration for automatic day-light savings time adjustment to occur at 2:00 a.m. local time on configured start and stop dates

Power Failure Backup: 24 hours at 32 to 122° F (0 to 50° C)

Accuracy: ± 1 minute per month at 77° F (25° C)

Digital Input (DI) Circuits

Voltage Rating: 0 to 30 Vdc open circuit

Input Type: Dry contact to detect open and closed circuit

Operating Range: Open circuit = False; Closed circuit = True

Resistance: Open circuit > 3,000 Ohms; Closed circuit < 500 Ohms

Digital Triac Output (DO) Circuits

Voltage Rating: 20 to 30 Vac @ 50/60Hz

Current Rating: 25 mA to 500 mA continuous, and 800 mA (AC rms) for 60 milliseconds

Analog Output (AO) Circuits

All three analog outputs must be configured for either current or voltage. Configuring analog outputs individually for current or voltage is not possible.

ANALOG CURRENT OUTPUTS:

Current Output Range: 4.0 to 20.0 mA

Output Load Resistance: 550 Ohms maximum

ANALOG VOLTAGE OUTPUTS:

Voltage Output Range: 2.0 to 10.0 Vdc

Maximum Output Current: 10.0 mA

Analog outputs may be configured as digital outputs and operate as follows:

- False (0%) produces 0 Vdc, (0 mA)
- True (100%) produces the maximum 11 Vdc, (22 mA)

Universal Input (UI) Circuits

See Table 2 for the UI circuit specifications:

Table 2. Universal Input Circuit Specifications.

Input Type	Sensor Type	Operating Range
Room/Zone Discharge Air Outdoor Air Temperature	20K Ohm NTC	-40° F to 199° F (-40° C to 93° C)
Outdoor Air Temperature	C7031G ^a	-40° to 120°F (-40° to 49°C)
	C7041F ^a	-40° to 250°F (-40° to 121°C)
	PT1000 (IEC751 3850)	-40° F to 199° F (-40° C to 93° C)
T7770 Setpoint Potentiometer	500 Ohm to 10,500 Ohm	-4° DDC to +4° DDC (-8° DDF to +7° DDF) or 50° F to 90° F (10° C to 32° C)
Resistive Input	Generic	100 Ohms to 100K Ohms
Voltage Input	Transducer, Controller	0 - 10 Vdc
Discrete Input	Dry Contact closure	OpenCircuit \geq 3000Ohms ClosedCircuit < 3000Ohms

^a C7031G and C7041F are recommended for use with these controllers, due to improved resolution and accuracy when compared to the PT1000.

BEFORE INSTALLATION

The controller is available in three models. See Table 1.

Review the power, input, and output specifications on page 2 before installing the controller.

- Hardware driven by the Triac outputs must have a minimum current draw, when energized, of 25 mA and a maximum current draw of 500 mA.
- Hardware driven by the analog current outputs must have a maximum resistance of 550 Ohms, resulting in a maximum voltage of 11 volts when driven at 20 mA. If resistance exceeds 550 Ohms, voltages up to 18 Vdc are possible at the analog output terminal.

WARNING

Electrical Shock Hazard.
Can cause severe injury, death or property damage.

Disconnect power supply before beginning wiring or making wiring connections to prevent electrical shock or equipment damage.

INSTALLATION

The controller must be mounted in a position that allows clearance for wiring, servicing, removal, connection of the LonWorks® Bus Jack, and access to the Neuron® Service Pin (See Fig. 14 on page 14).

The controller may be mounted in any orientation.

IMPORTANT

Avoid mounting in areas where acid fumes or other deteriorating vapors can attack the metal parts of the controller, or in areas where escaping gas or other explosive vapors are present. See Fig. 4 and Fig. 5 on page 5 for mounting dimensions.

For the PVL6436AS model only, the actuator is mounted first and then the controller is mounted. For the other models, go to “Mount Controller” on page 5 to begin the installation.

Mount Actuator Onto Damper Shaft (PVL6436AS only)

The PVL6436AS controller includes the direct-coupled actuator with Declutch mechanism, which is shipped hard-wired to the controller (using digital outputs 7 and 8).

The actuator mounts directly onto the VAV box damper shaft and has up to 44 lb-in. (5 Nm) torque, 90-degree stroke, and 90 second timing at 60 Hz. The actuator is suitable for mounting onto a 3/8 to 1/2 in. (10 to 13 mm) square or round VAV box damper shaft. The minimum VAV box damper shaft length is 1-9/16 in. (40 mm).

The two mechanical end-limit set screws control the amount of rotation from 12° to 95°. These set screws must be securely fastened in place. To ensure tight closing of the damper, the shaft adapter has a total rotation stroke of 95°. See Fig. 1.

NOTE: The actuator is shipped with the mechanical end-limit set screws set to 95 degrees of rotation. Adjust the two set screws closer together to reduce the rotation travel. Each “hash mark” indicator on the bracket represents approximately 6.5° of rotation per side.

NOTE: The Declutch button, when pressed, allows you to rotate the universal shaft adapter. See Fig. 1.

IMPORTANT

Determine the damper rotation and opening angle prior to installation. See Fig. 2 below and Fig. 3 on page 4 for examples.

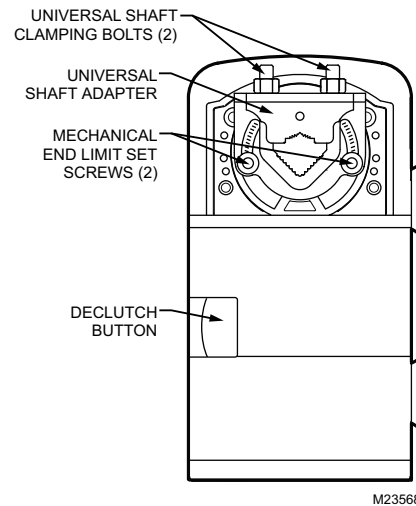

Fig. 1. Series 60 Floating Actuator.

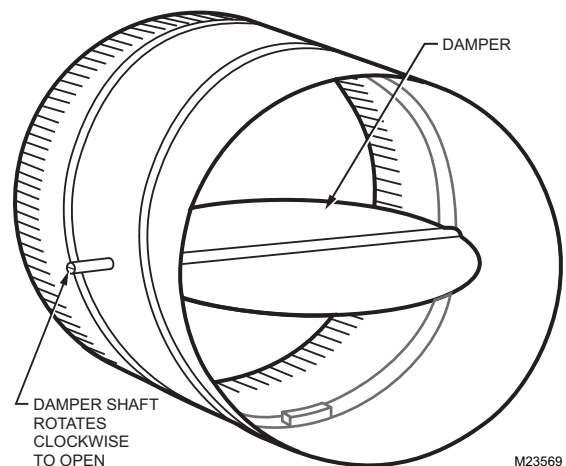

Fig. 2. Damper with 90 degree CW Rotation to Open.

IMPORTANT

Mount actuator flush with damper housing or add a spacer between the actuator mounting surface and damper box housing.

Before Mounting Actuator Onto Damper Shaft (PVL6436AS only)

Tools required:

- Phillips #2 screwdriver - end-limit set screw adjustment
- 8 mm wrench - centering clamp

Before mounting the actuator onto the VAV box damper shaft, determine the following:

1. Determine the damper shaft diameter. It must be between 3/8 in. to 1/2 in. (10 to 13 mm).
2. Determine the length of the damper shaft. If the length of the VAV box damper shaft is less than 1-9/16 in. (40 mm), the actuator cannot be used.
3. Determine the direction the damper shaft rotates to open the damper (CW or CCW); see Fig. 3. Typically, there is an etched line on the end of the damper shaft that indicates the position of the damper. In Fig. 2 on page 3, the indicator shows the damper open in a CW direction.
4. Determine the damper full opening angle (45, 60, or 90 degrees). In Fig. 2, the damper is open to its full open position of 90 degrees.

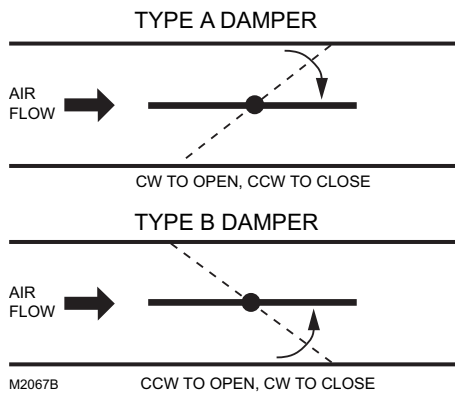

Fig. 3. Determining rotation direction (CW or CCW) for damper opening.

Mounting Actuator Onto Damper Shaft (PVL6436AS only)

The unit is shipped with the actuator set to rotate open in the clockwise (CW) direction to a full 95 degrees. The extra 5 degrees ensures a full opening range for a 90 degree damper. The installation procedure varies depending on the damper opening direction and angle:

1. If the damper rotates clockwise (CW) to open, and the angle of the damper open-to-closed is 90 degrees:
 - a. Manually open the damper fully (rotate clockwise).
 - b. Using the Declutch button, rotate the universal shaft adapter fully clockwise.
 - c. Mount the actuator to the VAV damper box and shaft.
 - d. Tighten the two bolts on the centering clamp (8 mm wrench; 70.8-88.5 lb-in. [8-10 Nm] torque). When the actuator closes, the damper rotates CCW 90 degrees to fully close.

2. If the damper rotates clockwise (CW) to open, and the angle of the damper open-to-closed is 45 or 60 degrees:
 - a. Manually open the damper fully (rotate clockwise).
 - b. The actuator is shipped with the mechanical end-limits set at 95 degrees. Adjust the two mechanical end-limit set screws to provide the desired amount of rotation. Adjust the two set screws closer together to reduce the rotation travel.
 - c. Tighten the two mechanical end-limit screws (Phillips #2 screwdriver; (26.5-31 lb-in. [3.0-3.5 Nm] torque).
 - d. Using the Declutch button, rotate the universal shaft adapter fully clockwise.
 - e. Mount the actuator to the VAV damper box and shaft.
 - f. Tighten the two bolts on the centering clamp (8 mm wrench; 70.8-88.5 lb-in. [8-10 Nm] torque).
 - g. When the actuator closes, the damper rotates CCW either 45 or 60 degrees to fully close.
3. If the damper rotates counterclockwise (CCW) to open, and the angle of the damper open-to-closed is 90 degrees:
 - a. Manually open the damper fully (rotate counter clockwise).
 - b. Using the Declutch button, rotate the universal shaft adapter fully counterclockwise.
 - c. Mount the actuator to the damper box and shaft.
 - d. Tighten the two bolts on the centering clamp (8 mm wrench; 70.8-88.5 lb-in. [8-10 Nm] torque). When the actuator closes, the damper rotates CW 90 degrees to fully close.
4. If the damper rotates counterclockwise (CCW) to open, and the angle of the damper open-to-closed is 45 or 60 degrees:
 - a. Manually open the damper fully (rotate counter-clockwise).
 - b. The actuator is shipped with the mechanical end-limits set at 95 degrees. Adjust the two mechanical end-limit set screws to provide the desired amount of rotation. Adjust the two set screws closer together to reduce the rotation travel.
 - c. Tighten the two mechanical end-limit screws (Phillips #2 screwdriver; (26.5-31 lb-in. [3.0-3.5 Nm] torque).
 - d. Using the Declutch button, rotate the universal shaft adapter fully counter-clockwise.
 - e. Mount the actuator to the VAV damper box and shaft.
 - f. Tighten the two bolts on the centering clamp (8 mm wrench; 70.8-88.5 lb-in. [8-10 Nm] torque).
 - g. When the actuator closes, the damper rotates CW either 45 or 60 degrees to fully close.

IMPORTANT

Special precautions must be taken for dampers that open in a CCW direction. The actuator is shipped with its rotation direction set to CW to Open, which applies to the damper direction in steps 1 and 2 above. If the damper shaft rotates in the CCW direction to open, the controller software must be programmed to change the rotation to "Reverse to Open," which applies to the damper direction in steps 3 and 4 above.

IMPORTANT

It is advisable to leave the dampers in an open position after installation to avoid the possibility of over-pressurizing the duct work on fan startup. Use the Declutch button (see Fig. 1 on page 3) to open the box damper on controllers that are powered down, to prevent over-pressurization in the duct work on fan startup. To Declutch, press and hold the button to disengage the motor. Turn the damper shaft until the damper is open and release the button. When power is restored to the controller, the controller synchronizes the damper actuator, so that the damper is in the correct position upon startup.

Mount Controller

NOTE: The controller may be wired before mounting to a panel or DIN rail.

Terminal blocks are used to make all wiring connections to the controller. Attach all wiring to the appropriate terminal blocks. See "Wiring" on page 9.

See Fig. 4 and Fig. 5 for panel mounting dimensions. See Fig. 6 on page 6 for DIN rail mounting.

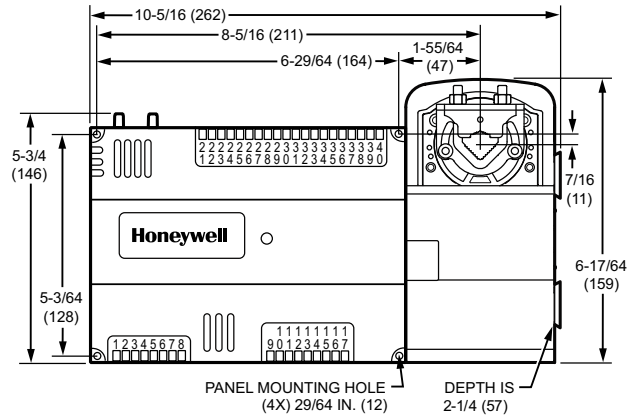

NOTE: CONTROLLER CAN BE MOUNTED IN ANY ORIENTATION. M23590

Fig. 4. Panel Mounting - Controller and Actuator Dimensions in inches (mm)—Model PVL6436AS only.

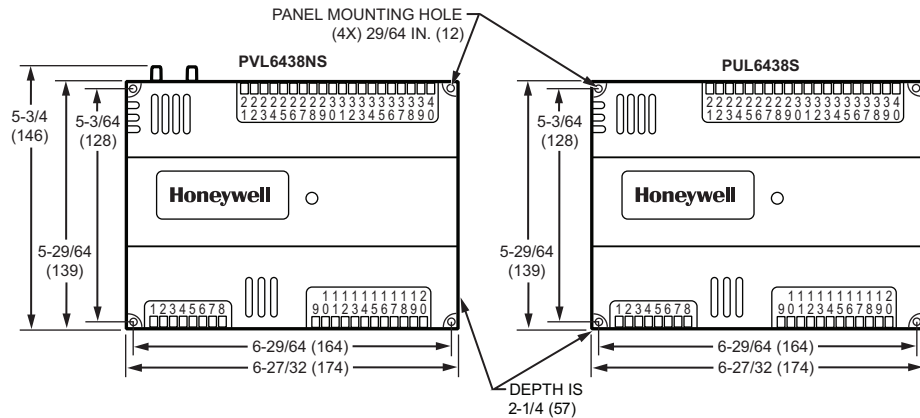

NOTE: CONTROLLER CAN BE MOUNTED IN ANY ORIENTATION. M23589A

Fig. 5. Panel Mounting - Controller Dimensions in inches (mm)—Models PVL6438NS and PUL6438S only.

Panel Mounting

The controller enclosure is constructed of a plastic base plate and a plastic factory-snap-on cover.

NOTE: The controller is designed so that the cover does not need to be removed from the base plate for either mounting or wiring.

The controller mounts using four screws inserted through the corners of the base plate. Fasten securely with four No. 6 or No. 8 machine or sheet metal screws.

The controller can be mounted in any orientation. Ventilation openings are designed into the cover to allow proper heat dissipation, regardless of the mounting orientation.

DIN Rail Mounting (PVL6438NS and PUL6438S Only)

To mount the PVL6438NS or PUL6438S controller on a DIN rail [standard EN50022; 1-3/8 in. x 9/32 in. (7.5 mm x 35 mm)], refer to Fig. 6 and perform the following steps:

1. Holding the controller with its top tilted in towards the DIN rail, hook the two top tabs on the back of the controller onto the top of the DIN rail.
2. Push down and in to snap the two bottom flex connectors of the controller onto the DIN rail.

IMPORTANT

To remove the controller from the DIN rail, perform the following:

1. Push straight up from the bottom to release the top tabs.
2. Rotate the top of the controller out towards you and pull the controller down and away from the DIN rail to release the bottom flex connectors.

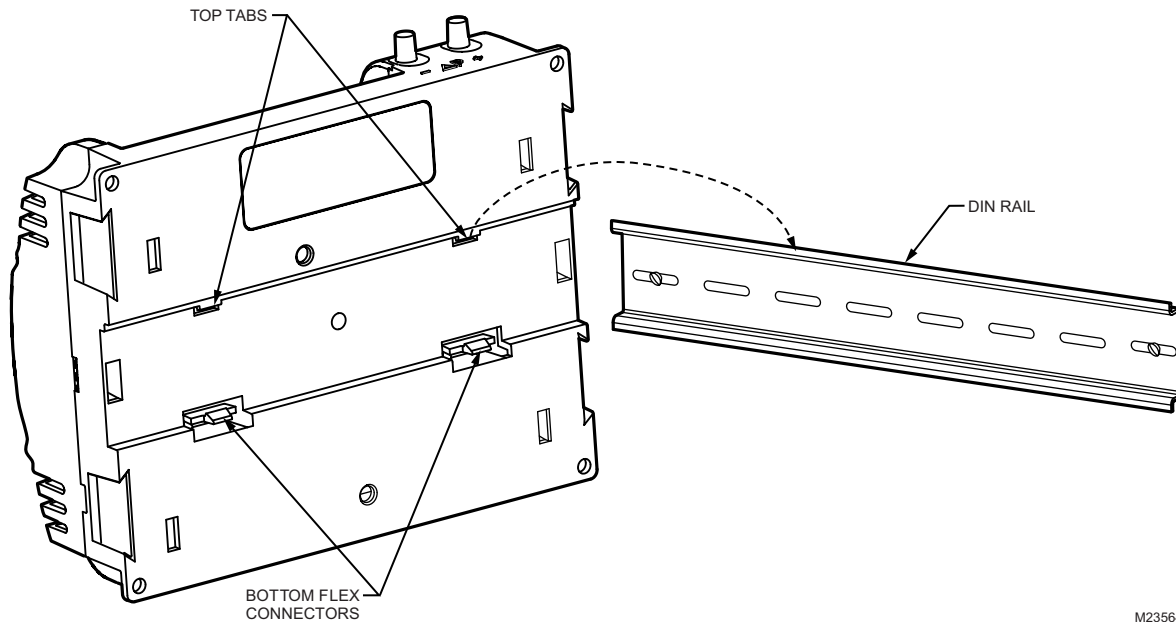

Fig. 6. Controller DIN rail mounting (Models PVL6438NS and PUL6438S only).

Piping (PVL6436AS and PVL6438NS only)

Air flow Pickup

For PVL6436AS and PVL6438NS only, connect the air flow pickup to the two restrictor ports on the controller. See Fig. 7 on page 7.

NOTES:

- Use 1/4 inch (6 mm) outside diameter, with a 0.040 in. (1 mm) wall thickness, plenum-rated 1219 FR (94V-2) tubing.
- Always use a fresh cut on the end of the tubing that connects to the air flow pickups and the restrictor ports on the controller.

Connect the high pressure or upstream tube to the plastic restrictor port labeled (+), and the low pressure or downstream tube to the restrictor port labeled (-). See labeling in Fig. 7. When twin tubing is used from the pickup, split the pickup tubing a short length to accommodate the connections.

NOTES:

- If controllers are mounted in unusually dusty or dirty environments, an inline, 5-micron disposable air filter^a is recommended for the high pressure line (marked as +) connected to the air flow pickup.
- The tubing from the air flow pickup to the controller should not exceed three feet (0.914 m). Any length greater than this will degrade the flow sensing accuracy.
- Use caution when removing tubing from a connector. Always pull straight away from the connector or use diagonal cutters to cut the edge of the tubing attached to the connector. Never remove by pulling at an angle.

^a Use 5-micron filters compatible with pneumatic controls.

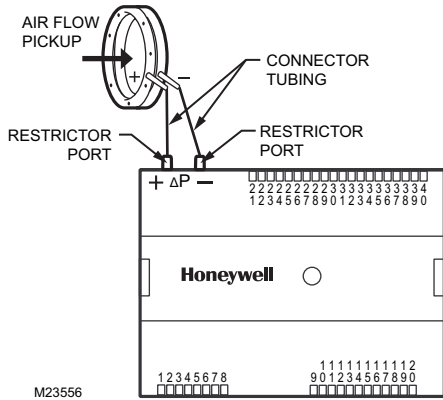

Fig. 7. Air flow pickup connections (PVL6436AS and PVL6438NS only).

Power

Before wiring the controller, determine the input and output device requirements for each controller used in the system. Select input and output devices compatible with the controller and the application. Consider the operating range, wiring requirements, and the environment conditions when selecting input/output devices. When selecting actuators for modulating applications consider using floating control. In direct digital control applications, floating actuators will generally provide control action equal to or better than an analog input actuator for lower cost.

Determine the location of controllers, sensors, actuators and other input/output devices and create wiring diagrams. Refer to Fig. 15–Fig. 21 beginning on page 15 for illustrations of typical controller wiring for various configurations.

The application engineer must review the control job requirements. This includes the sequences of operation for the controller, and for the system as a whole. Usually, there are variables that must be passed between the controller and other Excel 10 controller(s) that are required for optimum system wide operation. Typical examples are the TOD, Occ/Unocc signal, the outdoor air temperature, the demand limit control signal, and the smoke control mode signal.

It is important to understand these interrelationships early in the job engineering process, to ensure proper implementation when configuring the controllers. Refer to the controller Application Guides.

Power Budget

A power budget must be calculated for each device to determine the required transformer size for proper operation. A power budget is simply the summing of the maximum power draw ratings (in VA) of all the devices to be controlled. This includes the controller itself and any devices powered from the controller, such as equipment actuators (ML6161 or other motors) and various contactors and transducers.

IMPORTANT

- If a controller is used on Heating and Cooling Equipment (UL 1995, U.S. only) and transformer primary power is more than 150 volts, connect the transformer secondary common to earth ground. See Fig. 10 on page 10.
- When multiple controllers operate from a single transformer, connect the same side of the transformer secondary to the same power input terminal in each device. The earth ground terminal (terminal 3) must be connected to a verified earth ground for each controller in the group. See Fig. 11 on page 10.

POWER BUDGET CALCULATION EXAMPLE

Table 3 is an example of a power budget calculation for a typical PVL6436AS controller. While the example is shown for a PVL6436AS, the process is applicable for all controller models.

Table 3. Power Budget Calculation Example.

Device	VA Information	Obtained From
PVL6436AS Controller (includes Series 60 Floating Damper Actuator)	21.0	See “Specifications” on page 2.
R8242A Contactor fan rating	21.0	TRADELIN [®] Catalog inrush rating
D/X Stages	0.0	For example, assume cooling stage outputs are wired into a compressor control circuit and have no impact on the budget.
M6410A Steam Heating Coil Valve	0.7	TRADELIN [®] Catalog, 0.32A 24 Vac
TOTAL	42.7	

The system example above requires 42.7 VA of peak power. Therefore, a 100 VA AT92A transformer could be used to power one controller of this type. Because the total peak power is less than 50 VA, this same transformer could be used to power two of these controllers and meet NEC Class 2 restrictions (no greater than 100 VA).

See Fig. 9–Fig. 11 on page 10 for illustrations of controller power wiring. See Table 4 for VA ratings of various devices.

Table 4. VA Ratings for Transformer Sizing.

Device	Description	VA
PVL6436AS Controller and Series 60 Floating Damper Actuator	Controller and Actuator	21.0
PVL6438NS or PUL6438S	Controller	20.0
ML6161	Damper Actuator, 35 lb-in.	2.2
R8242A	Contactora	21.0
R6410A	Valve Actuator	0.7
ML684	Versadrive Valve Actuator	12.0
ML6464	Damper Actuator, 66 lb-in.	3.0
ML6474	Damper Actuator, 132 lb-in.	3.0
ML6185	Damper Actuator SR 50 lb-in	12.0

For contactors and similar devices, the in-rush power ratings should be used as the worst case values when performing power budget calculations. Also, the application engineer must consider the possible combinations of simultaneously energized outputs and calculate the VA ratings accordingly. The worst case, which uses the largest possible VA load, should be determined when sizing the transformer.

Each controller requires 24 Vac power from an energy-limited Class II power source. To conform to Class II restrictions (U.S. only), transformers must not be larger than 100 VA. A single transformer can power more than one controller.

GUIDELINES FOR POWER WIRING ARE AS FOLLOWS:

- For multiple controllers operating from a single transformer, the same side of the transformer secondary must be connected to the same power input terminal in each device. The earth ground terminal must be connected to a verified earth ground for each controller in the group. See Fig. 11 on page 10. Controller configurations are not necessarily limited to two devices. But the total power draw, including accessories, cannot exceed 100 VA when powered by the same transformer (U.S. only).
- See Fig. 10 on page 10 for controller power wiring used in UL 1995 equipment (U.S. only).
- Many controllers require all loads to be powered by the same transformer that powers the controller.
- Keep the earth ground connection wire run as short as possible. Refer to Fig. 9–Fig. 11 on page 10.
- Do not connect earth ground to the controller’s digital or analog ground terminals. Refer to Fig. 9 and Fig. 11 on page 10.
- Unswitched 24 Vac power wiring can be run in the same conduit as the LONWORKS® Bus cable.
- Maintain at least a 3 in. (76 mm) separation between Triac outputs and LONWORKS® Bus wiring throughout the installation.

Line-Loss

Controllers must receive a minimum supply voltage of 20 Vac. If long power or output wire runs are required, a voltage drop due to Ohms Law (I x R) line-loss must be considered. This

line-loss can result in a significant increase in total power required and thereby affect transformer sizing. The following example is an I x R line-loss calculation for a 200 ft. (61m) run from the transformer to a controller drawing 37 VA and using two 18 AWG (1.0 sq mm) wires.

The formula is:

$$\text{Loss} = [\text{length of round-trip wire run (ft.)}] \times [\text{resistance in wire (ohms per ft.)}] \times [\text{current in wire (amperes)}]$$

From specification data:

18 AWG twisted pair wire has a resistance of 6.52 ohms per 1000 feet.

$$\text{Loss} = [(400 \text{ ft.}) \times (6.52/1000 \text{ ohms per ft.})] \times [(37 \text{ VA}) / (24\text{V})] = 4.02 \text{ volts}$$

This means that four volts are going to be lost between the transformer and the controller. To assure the controller receives at least 20 volts, the transformer must output more than 24 volts. Because all transformer output voltage levels depend on the size of the connected load, a larger transformer outputs a higher voltage than a smaller one for a given load. Fig. 8 on page 9 shows this voltage load dependence.

In the preceding I x R loss example, even though the controller load is only 37 VA, a standard 40 VA transformer is not sufficient due to the line-loss. Looking at Fig. 8 on page 9, a 40 VA transformer is just under 100 percent loaded (for the 37 VA controller) and has a secondary voltage of 22.9 volts. (Use the lower edge of the shaded zone in Fig. 8 that represents the worst case conditions.) When the I x R loss of four volts is subtracted, only 18.9 volts reaches the controller. This is not enough voltage for proper operation.

In this situation, the engineer has three alternatives:

1. Use a larger transformer. For example, if an 80 VA model is used, an output of 24.4 volts, minus the four volt line-loss, supplies 20.4V to the controller. See Fig. 8 on page 9. Although acceptable, the four-volt line-loss in this example is higher than recommended.

IMPORTANT

No installation should be designed where the line-loss is greater than two volts. This allows for nominal operation if the primary voltage drops to 102 Vac (120 Vac minus 15 percent).

2. Use heavier gauge wire for the power run. 14 AWG (2.0 sq mm) wire has a resistance of 2.57 ohms per 1,000 ft. Using the preceding formula results in a line-loss of only 1.58 volts (compared with 4.02 volts). This would allow a 40 VA transformer to be used. 14 AWG (2.0 sq mm) wire is the recommended wire size for 24 Vac wiring.
3. Locate the transformer closer to the controller. This reduces the length of the wire run, and the line-loss.

The issue of line-loss is also important in the case of the output wiring connected to the Triac digital outputs. The same formula and method are used. Keep all power and output wire runs as short as practical. When necessary, use heavier gauge wire, a bigger transformer, or install the transformer closer to the controller.

To meet the National Electrical Manufacturers Association (NEMA) standards, a transformer must stay within the NEMA limits. The chart in Fig. 8 shows the required limits at various loads.

With 100 percent load, the transformer secondary must supply between 23 and 25 volts to meet the NEMA standard. When a purchased transformer meets the NEMA standard DC20-1986, the transformer voltage regulating ability can be considered reliable. Compliance with the NEMA standard is voluntary.

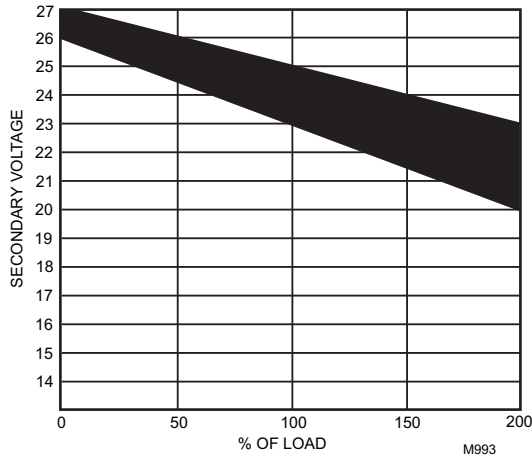

Fig. 8. NEMA Class 2 Transformer Voltage Output Limits.

The Honeywell transformers listed in Table 5 meet the NEMA standard DC20-1986.

Table 5.

Transformer Type	VA Rating
AT40A	40
AT72D	40
AT87A	50
AK3310 Assembly	100

NOTE: The AT88A and AT92A transformers do not meet the voluntary NEMA standard DC20-1986.

Wiring

All wiring must comply with applicable electrical codes and ordinances, or as specified on installation wiring diagrams. Controller wiring is terminated to the screw terminal blocks located on the top and the bottom of the device.

⚠️ WARNING

Electrical Shock Hazard.
Can cause severe injury, death or property damage.

Disconnect power supply before beginning wiring, or making wiring connections, to prevent electrical shock or equipment damage.

NOTES:

- For multiple controllers operating from a single transformer, the same side of the transformer secondary must be connected to the same power input terminal in each controller. (Controller configurations will not necessarily be limited to three devices. But the total power draw, including accessories, can not exceed 100 VA when powered by the same transformer (U.S. only). For power and wiring recommendations—See “Power” on page 7. The earth ground terminal (terminal 3) must be connected to a verified earth ground for each controller in the group. See Fig. 11 on page 10.
- All loads on the controller must be powered by the same transformer that powers the controller itself. A controller can use separate transformers for controller power and output power.
- Keep the earth ground connection (terminal 3) wire run as short as possible.
- Do not connect the universal input COM terminals (33, 36, 39), analog output COM terminals (22, 25) or the digital input/output COM terminals (11, 14, 17, 20, 28) to earth ground. Refer to Fig. 15—Fig. 20 beginning on page 15 for wiring examples.

The 24 Vac power from an energy limited Class II power source must be provided to the controller. To conform to Class II restrictions (U.S. only), the transformer must not be larger than 100 VA.

Fig. 9 on page 10 depicts a single controller using one transformer.

IMPORTANT

Power must be off prior to connecting to or removing connections from terminals 1, 2, 3, and 31.

IMPORTANT

Use the heaviest gauge wire available, up to 14 AWG (2.0 sq mm), with a minimum of 18 AWG (1.0 sq mm), for all power and earth ground wiring.

Screw-type terminal blocks are designed to accept up to one 14 AWG (2.0 sq mm) conductor or up to two 18 AWG (1.0 sq mm) conductors. More than two wires that are 18 AWG (2.0 sq mm) can be connected with a wire nut. Include a pigtail with this wire group and attach the pigtail to the terminal block.

IMPORTANT

If the controller is used on **Heating and Cooling Equipment (UL 1995, U.S. only)** and the transformer primary power is more than 150 volts, connect terminal 2, (the 24 Vac common (24 VAC COM) terminal) to earth ground, see Fig. 10. For these applications, only one controller can be powered by each transformer.

NOTES:

- Unswitched 24 Vac power wiring can be run in the same conduit as the LONWORKS® cable.
- Maintain at least a 3 in. (7.6 cm) separation between Triac outputs and LONWORKS® wiring throughout the installation.

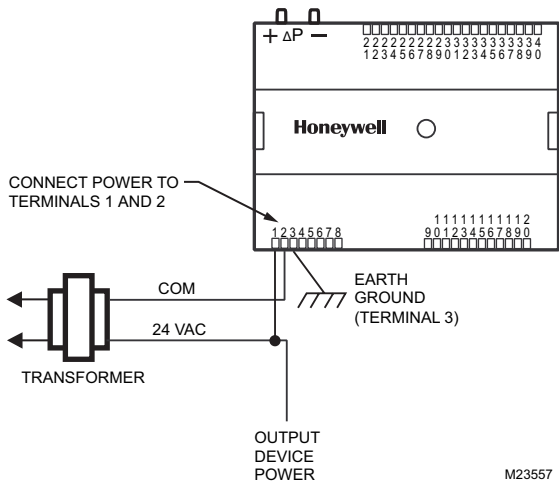

Fig. 9. Power wiring details for one controller per transformer.

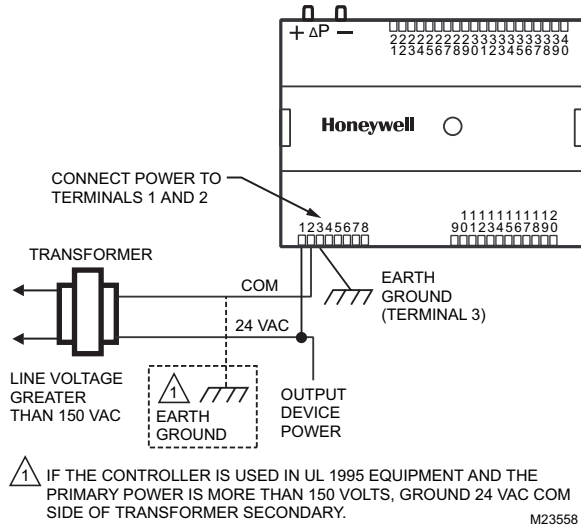

Fig. 10. Transformer power wiring details for one controller used in UL 1995 equipment (U.S. only).

More than one controller can be powered by a single transformer. Fig. 11 shows power wiring details for multiple controllers.

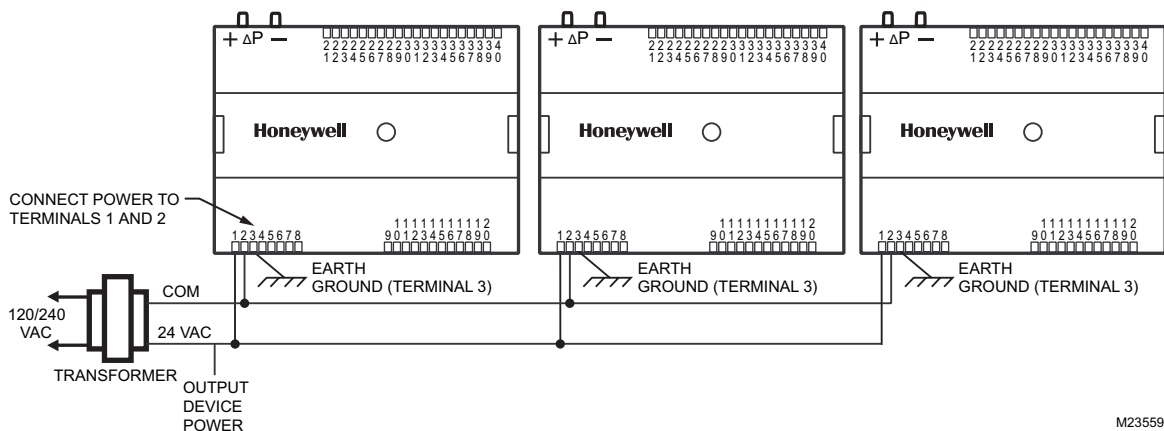

Fig. 11. Power wiring details for two or more controllers per transformer.

NOTE: Controller configurations are not necessarily limited to three devices. But the total power draw, including accessories, cannot exceed 100 VA when powered by the same transformer, U.S. only. For power wiring recommendations, see "Power" on page 7.

Communications

Refer to “LONWORKS® Wiring Guidelines,” form 74-2865, for a complete description of LONWORKS® Bus network topology rules and approved cable types.

Honeywell provided cable types for LONWORKS® Bus communications wiring are Level IV 22 AWG (0.34 sq mm) plenum or non-plenum rated unshielded, twisted pair, stranded conductor wire.

- For non-plenum areas, U.S. part AK3798 (single-pair stranded) can be used.
- In plenum areas, U.S. part AK3797 (single-pair stranded) or U.S. part AK3799 (two-pair stranded) can be used.

Contact Echelon Corp. Technical Support for the recommended vendors of Echelon approved cables.

Communications wiring can be run in a conduit, if needed, with non-switched 24 Vac or sensor wiring. If a longer LONWORKS® Bus network is required, a Q7751A,B router (configured as a repeater) can be added to extend the length of the LONWORKS® Bus. Each network segment can have a maximum of one repeater.

Pull the cable to each controller on the LONWORKS® Bus and connect to the controller's communication terminals 7 and 8. (See Table 6 on page 13 and Fig. 14 on page 14 for location of terminals 7 and 8.)

NOTE: Connection for operator access to the LONWORKS® Bus is provided by plugging the Serial LONTALK® Adapter (SLTA) connector into the LONWORKS® Bus jack. (See Fig. 14 on page 14)

IMPORTANT

Notes on Communications Wiring:

All field wiring must conform to local codes and ordinances (or as specified on installation drawings).

Do not bundle device output wires with sensor, digital input or communications LONWORKS® Bus wires.

Do not use different wire types or gauges on the same LONWORKS Bus segment. The step change in line impedance characteristics causes unpredictable reflections on the LONWORKS® Bus.

In noisy (high EMI) environments, avoid wire runs parallel to noisy power cables, motor control centers, or lines containing lighting dimmer switches. Keep at least 3 in. (76 mm) of separation between noisy lines and the LONWORKS® Bus cable.

The theoretical limit for each LONWORKS® Bus segment is 60 controllers. Up to 120 controllers can be configured when a repeater is used, and the bus must be either singly or doubly terminated. Actual installations may have a lower limit depending on the devices connected.

- *The singly terminated bus must have one 209541B Excel 10 FTT Termination Module for T tap or Star configurations.*
- *The doubly terminated bus must have two 209541B Excel 10 FTT Termination Modules, one at each end of the daisy chain (Bus style) wiring run. Note that the Q7751A,B router (configured as a repeater) has onboard terminating networks that can be jumper-selected on each segment.*

Make sure that neither of the LONWORKS® Bus wires are grounded.

NOTE: If a 209541B Termination Module is required at the controller, connect two of the three termination module wires to the LONWORKS® Bus terminals 7 and 8, which are labeled Net-1 and Net-2 on the controller. Selecting the appropriate two wires depends on the LONWORKS® Bus network topology. Refer to the “LONWORKS® Bus Wiring Guidelines,” form 74-2865, and the “Excel 10 FTT Termination Module Installation Instructions,” form 95-7554. For example, on a doubly terminated daisy-chained bus topology, where controllers are on either end of an LONWORKS® Bus wire run, mount the termination module on the appropriate terminals, as shown in Fig. 12 on page 12.

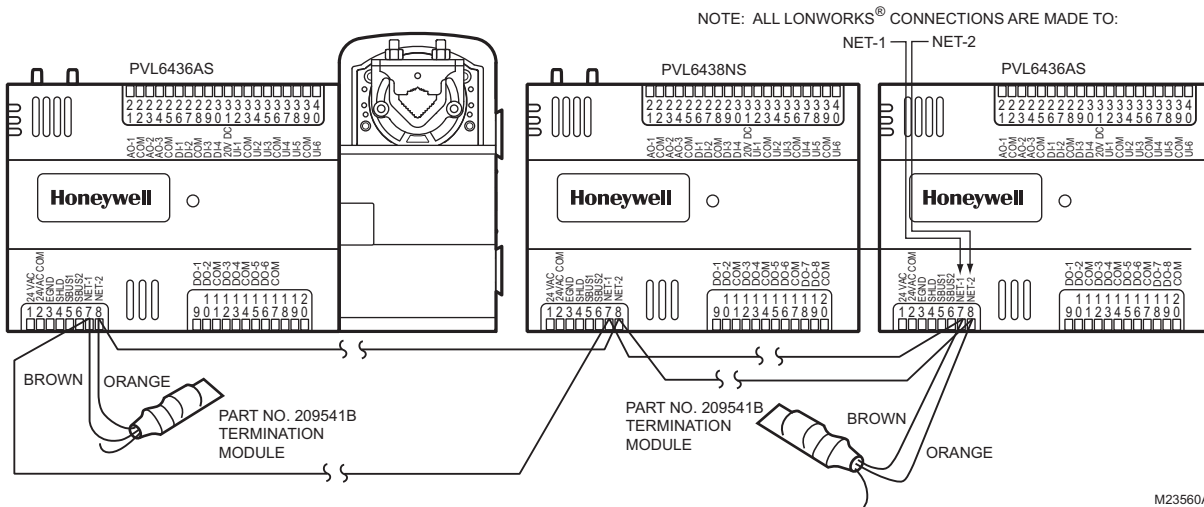

Fig. 12. Termination modules (LONWORKS® daisy chain connections).

Wiring Method

⚠ WARNING

Electrical Shock Hazard.
Can cause severe injury, death or property damage.

Disconnect power supply before beginning wiring, or making wiring connections, to prevent electrical shock or equipment damage.

NOTE: When attaching two or more wires to the same terminal, other than 14 AWG (2.0 sq mm), be sure to twist them together. Deviation from this rule can result in improper electrical contact. See Fig. 13.

Each terminal can accommodate the following gauges of wire:

- Single wire: from 22 AWG to 14 AWG solid or stranded
- Multiple wires: up to two 18 AWG stranded, with 1/4 watt wire-wound resistor

Prepare wiring for the terminal blocks, as follows:

1. Strip 1/2 in. (13 mm) insulation from the conductor.
2. Cut a single wire to 3/16 in. (5 mm). Insert the wire in the required terminal location and tighten the screw.
3. If two or more wires are being inserted into one terminal location, twist the wires together a minimum of three turns before inserting them. See Fig. 13.

4. Cut the twisted end of the wires to 3/16 in. (5 mm) before inserting them into the terminal and tightening the screw.
5. Pull on each wire in all terminals to check for good mechanical connection.

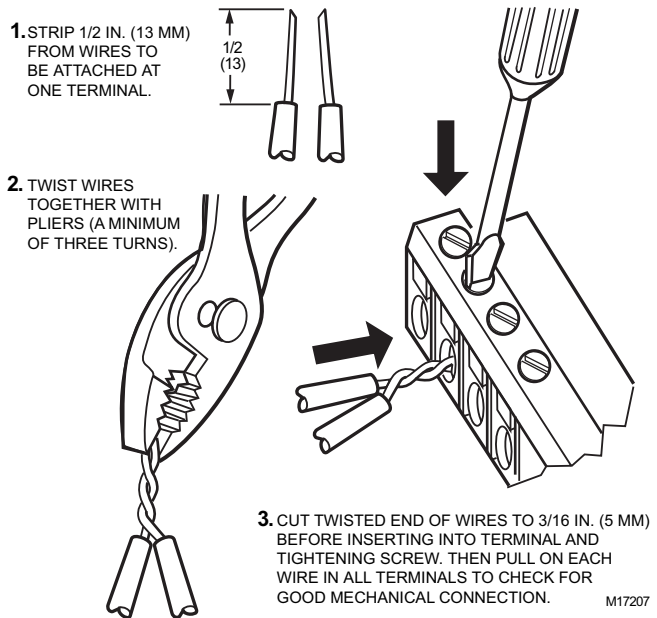

Fig. 13. Attaching two or more wires at terminal blocks.

Wiring Details

Each controller is shipped with the digital outputs, which switch the 24 Vac to the load (High Side).

The three analog outputs (AO) are used to control modulating heating, cooling and economizer equipment. Any AO may be used as a digital output, as follows:

- False (0%) produces 0 Vdc, (0 mA)
- True (100%) produces the maximum 11 Vdc (22 mA)

The wiring connection terminals described in Table 6 are shown in Fig. 14 on page 14.

Table 6. Description of Wiring Terminal Connections.

Terminal	Label	Connection
INPUT POWER & GROUND		
1	24 Vac	24 Vac Power
2	24 Vac COM	24 Vac Power
3	EGND	Earth Ground
4	SHLD	Shield
5	SBUS 1	Sylk
6	SBUS 2	Sylk
NETWORK CONNECTIONS		
7	NET-1	LONWORKS® communications
8	NET-2	LONWORKS® communications
DIGITAL OUTPUTS ^a		
9	DO-1	Digital Output
10	DO-2	Digital Output
11	COM	Common
12	DO-3	Digital Output
13	DO-4	Digital Output
14	COM	Common
15	DO-5	Digital Output
16	DO-6	Digital Output
17	COM	Common
18	DO-7	Digital Output
19	DO-8	Digital Output
20	COM	Common

^a For the PVL6436AS controller ONLY, terminals 18, 19, and 20 (DO7, DO8, & COM) are not present. The actuator is internally hardwired to these terminals.

^b Analog outputs may be configured as digital outputs and operate as follows:
 – False (0%) produces 0 Vdc, (0 mA)
 – True (100%) produces the maximum 11 Vdc (22 mA)

^c Digital inputs: Open circuit = False; Closed circuit = True

Table 6. Description of Wiring Terminal Connections. (Continued)

Terminal	Label	Connection
ANALOG OUTPUTS ^b		
21	AO-1	Analog Output
22	COM	Common
23	AO-2	Analog Output
24	AO-3	Analog Output
25	COM	Common
DIGITAL INPUTS ^c		
26	DI-1	Digital Input
27	DI-2	Digital Input
28	COM	Common
29	DI-3	Digital Input
30	DI-4	Digital Input
ATTACHED DEVICE(S) POWER		
31	20 Vdc	20 Vdc Power
UNIVERSAL INPUTS		
32	UI-1	Universal Input
33	COM	Common
34	UI-2	Universal Input
35	UI-3	Universal Input
36	COM	Common
37	UI-4	Universal Input
38	UI-5	Universal Input
39	COM	Common
40	UI-6	Universal Input

^a For the PVL6436AS controller ONLY, terminals 18, 19, and 20 (DO7, DO8, & COM) are not present. The actuator is internally hardwired to these terminals.

^b Analog outputs may be configured as digital outputs and operate as follows:
 – False (0%) produces 0 Vdc, (0 mA)
 – True (100%) produces the maximum 11 Vdc (22 mA)

^c Digital inputs: Open circuit = False; Closed circuit = True

IMPORTANT

If the controller is not connected to a good earth ground, the controller's internal transient protection circuitry is compromised and the function of protecting the controller from noise and power line spikes cannot be fulfilled. This could result in a damaged circuit board and require replacement of the controller. Refer to installation diagrams for specific wiring.

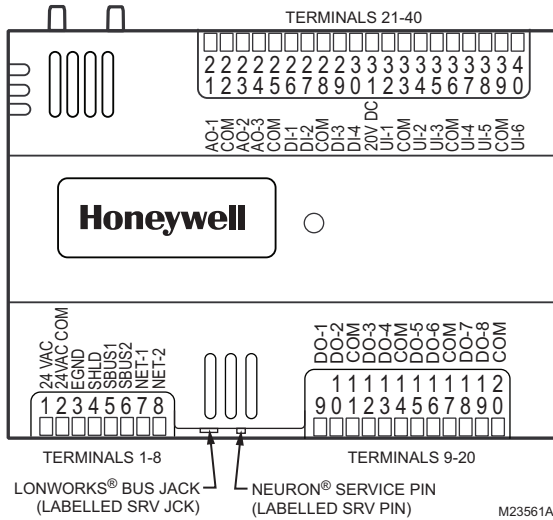

Fig. 14. Controller Terminal Connections, NEURON® Service Pin, & LONWORKS® Bus Jack (PVL6438NS shown).

All controllers have the terminal arrangement shown in Fig. 14 and Table 6, with the following exception.

NOTE: For the PVL6436AS controller ONLY, terminals 18, 19, and 20 are not present. This is because the actuator is hard wired inside the controller and uses the digital outputs and COM circuits assigned to terminals 18, 19, and 20.

NEURON® SERVICE PIN

The NEURON® Service Pin pushbutton (when pressed) transmits the Service Message to the network, regardless of the controller’s current mode of operation. (See Fig. 14).



CAUTION

Equipment Damage Hazard.

Can cause controller damage or failure.

Do not use any metal object to press the NEURON® Service Pin. Use a plastic rod or wood device (such as a pencil with the lead broken off) to press the pin. Using a metal object can damage the circuitry of the controller.

LONWORKS BUS CONVENIENCE JACK

The LONWORKS Bus connection is provided by plugging the Serial LONTALK® Adapter (SLTA) connector into the LONWORKS® Bus Jack. (See Fig. 14)

Wiring Applications (Examples)

Fig. 15–Fig. 21, beginning on page 15, illustrate typical controller wiring for the following configurations.

- Typical controller wiring for VAV application using the T7770C Wall Module and a C7770A Air Temperature Sensor—See Fig. 15 on page 15.
- Typical controller wiring for VAV application with staged reheat—See Fig. 16 on page 16.
- Typical controller wiring for PWM reheat and PWM peripheral heat valve actuator—See Fig. 17 on page 17.
- Typical controller wiring for AHU application—See Fig. 18 on page 18.
- Typical controller wiring for 4 to 20 mA enthalpy sensors and digital inputs—See Fig. 19 on page 19.
- Typical controller wiring for 4 to 20 mA heating, cooling, and model ML6161 floating motor control—See Fig. 20 on page 20.
- Typical controller wiring for a pneumatic transducer, model RP7517B—See Fig. 21 on page 21.

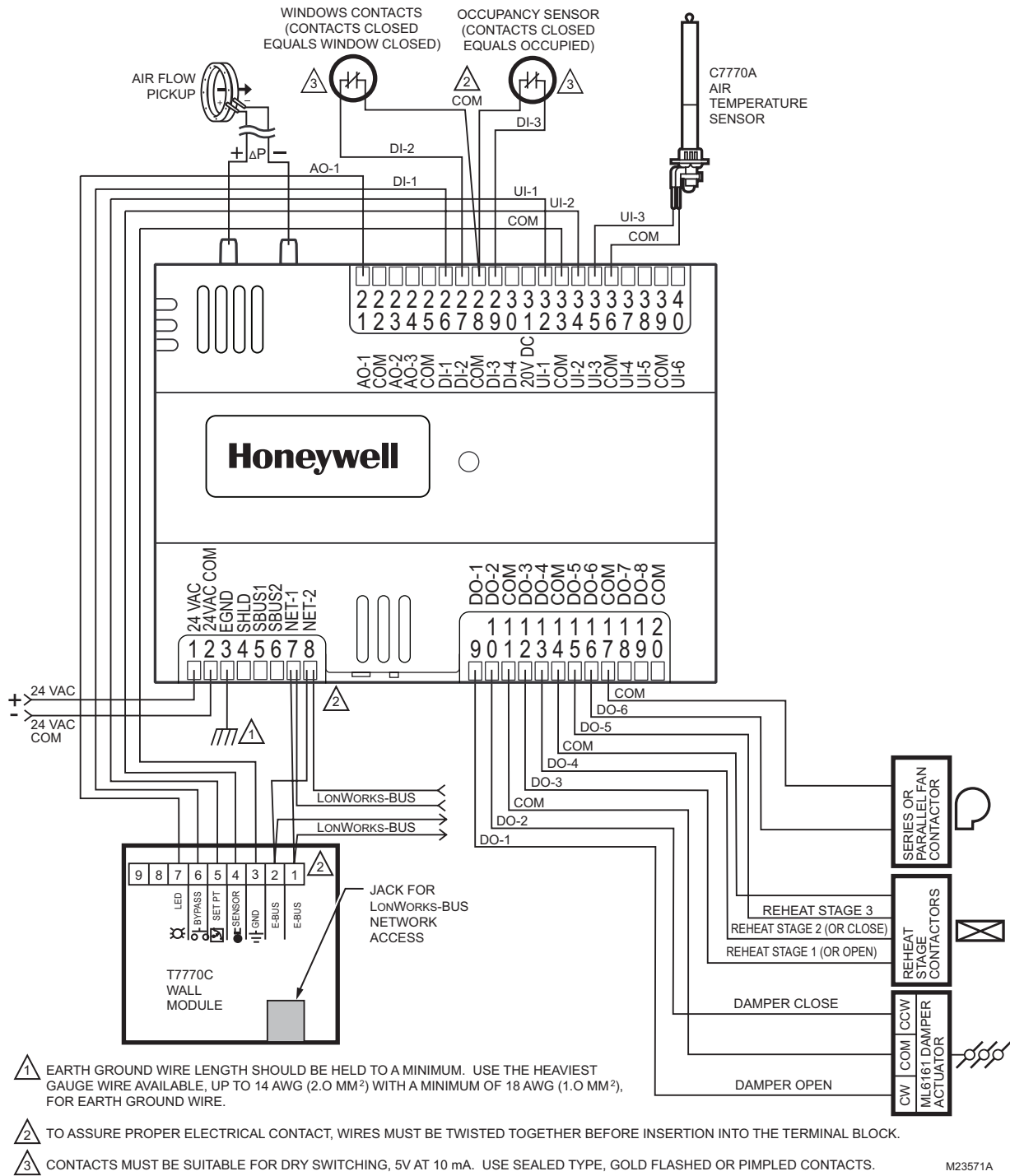
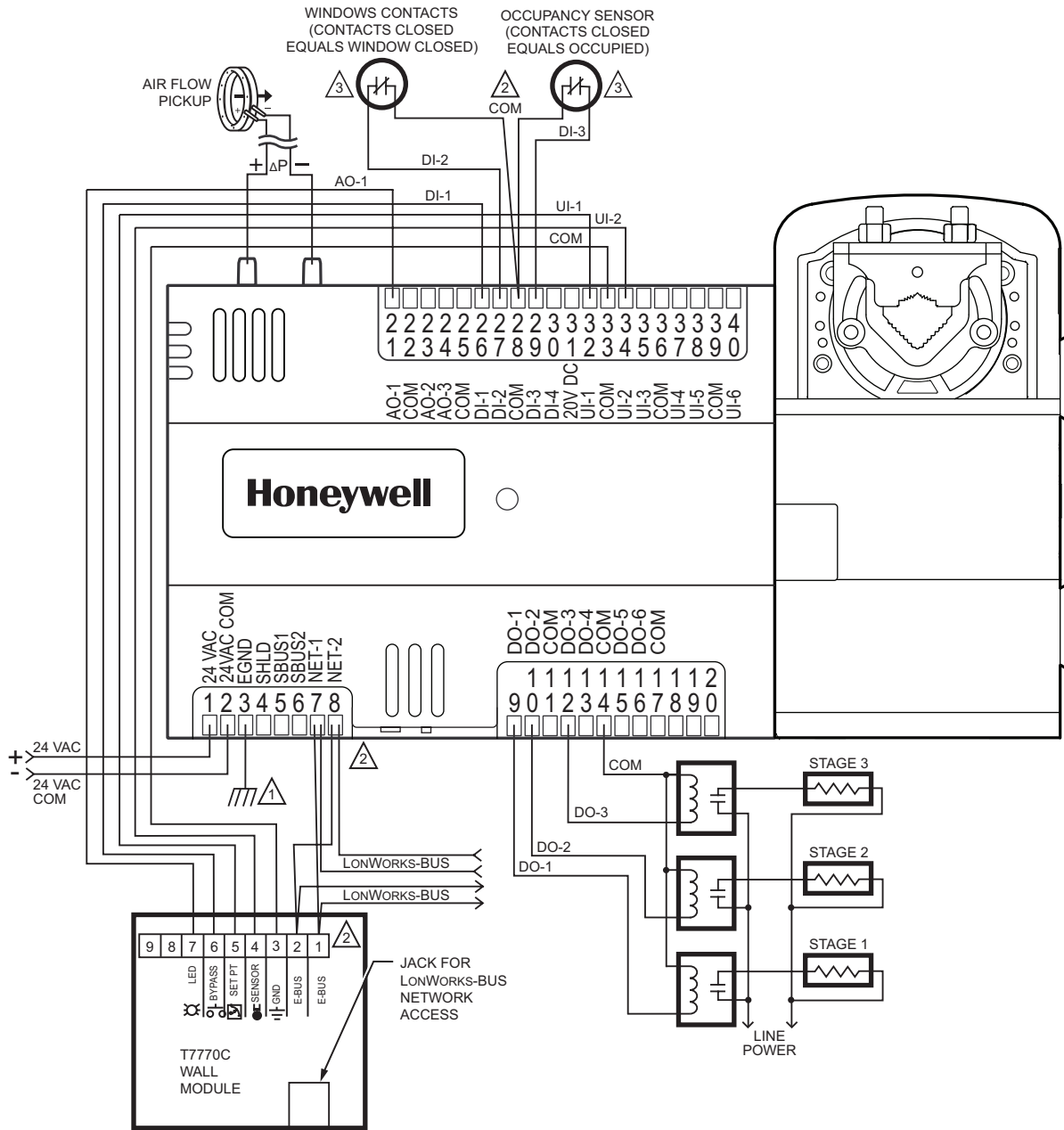

Fig. 15. Controller wiring diagram (model PVL6438NS shown) for typical VAV application, using the T7770C Wall Module and a C7770A Air Temperature Sensor. (For note 2, refer to Fig. 13.)



⚠ EARTH GROUND WIRE LENGTH SHOULD BE HELD TO A MINIMUM. USE THE HEAVIEST GAUGE WIRE AVAILABLE, UP TO 14 AWG (2.0 MM²) WITH A MINIMUM OF 18 AWG (1.0 MM²), FOR EARTH GROUND WIRE.

⚠ TO ASSURE PROPER ELECTRICAL CONTACT, WIRES MUST BE TWISTED TOGETHER BEFORE INSERTION INTO THE TERMINAL BLOCK.

⚠ CONTACTS MUST BE SUITABLE FOR DRY SWITCHING, 5V AT 10 mA. USE SEALED TYPE, GOLD FLASHED OR PIMPLED CONTACTS.

M23572A

Fig. 16. Controller wiring diagram (model PVL6436AS shown) for typical VAV application with Staged Reheat. (For note 2, refer to Fig. 13.)

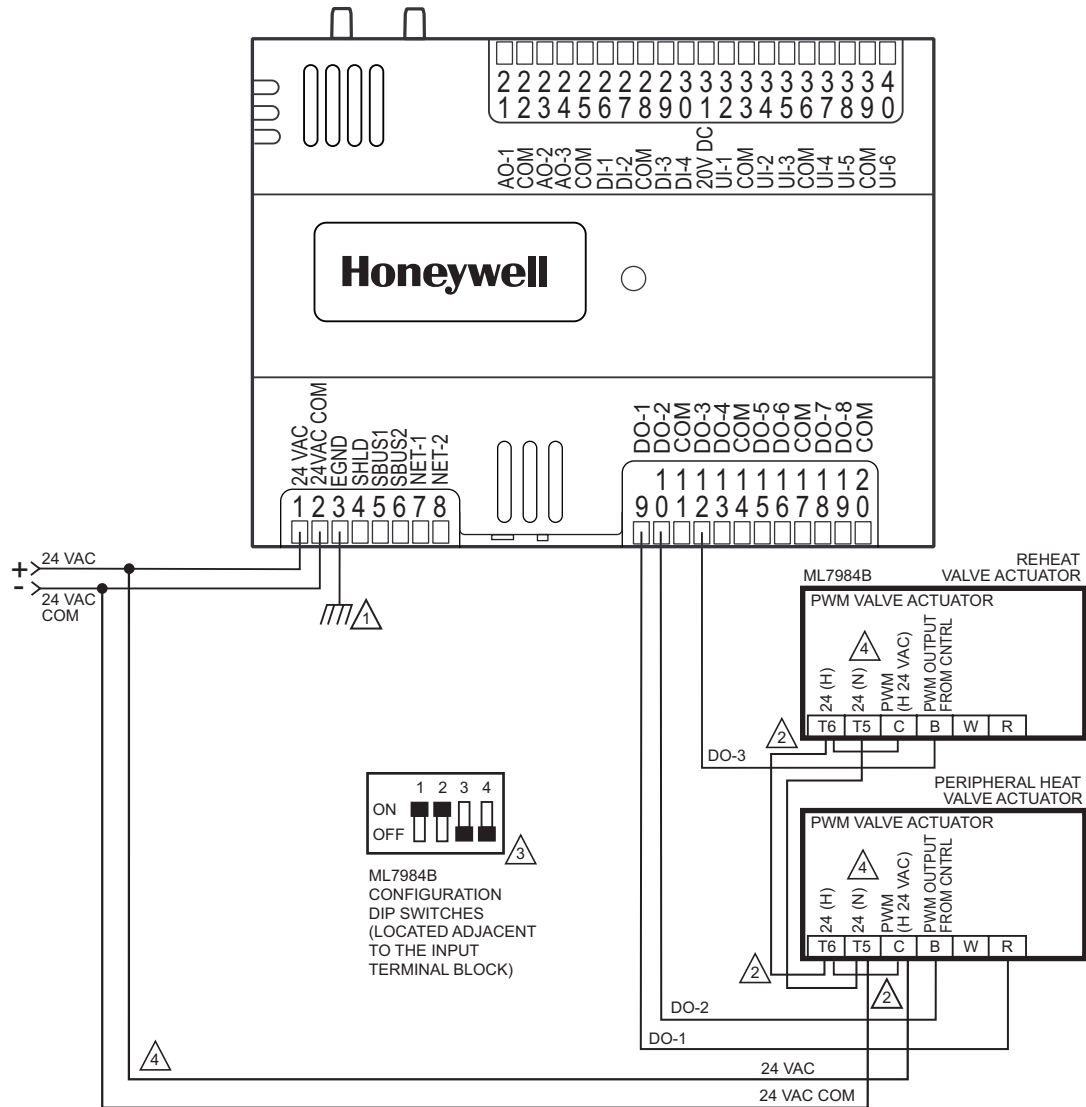

- 1 EARTH GROUND WIRE LENGTH SHOULD BE HELD TO A MINIMUM. USE THE HEAVIEST GAUGE WIRE AVAILABLE, UP TO 14 AWG (2.0 MM²) WITH A MINIMUM OF 18 AWG (1.0 MM²), FOR EARTH GROUND WIRE.
- 2 TO ASSURE PROPER ELECTRICAL CONTACT, WIRES MUST BE TWISTED TOGETHER BEFORE INSERTION INTO THE TERMINAL BLOCK.
- 3 TURN POWER OFF BEFORE SETTING THE DIP SWITCHES.
- 4 MAKE SURE ALL TRANSFORMER/POWER WIRING IS AS SHOWN: REVERSING TERMINATIONS WILL RESULT IN EQUIPMENT MALFUNCTION.

M23573A

Fig. 17. Controller wiring diagram (model PUL6438S shown) for typical PWM reheat and PWM peripheral heat valve actuator. (For note 2, refer to Fig. 13.)

NOTE: Make sure to set the Configuration DIP Switch as shown in Fig. 17. Switches 1 through 3 set the timing of the ML7984B valve actuator to match the controller outputs (0.1 second minimum with a maximum

time of 25.6 seconds). Switch 4 determines the action of the actuator (Off = Direct Acting, On = Reverse Acting).

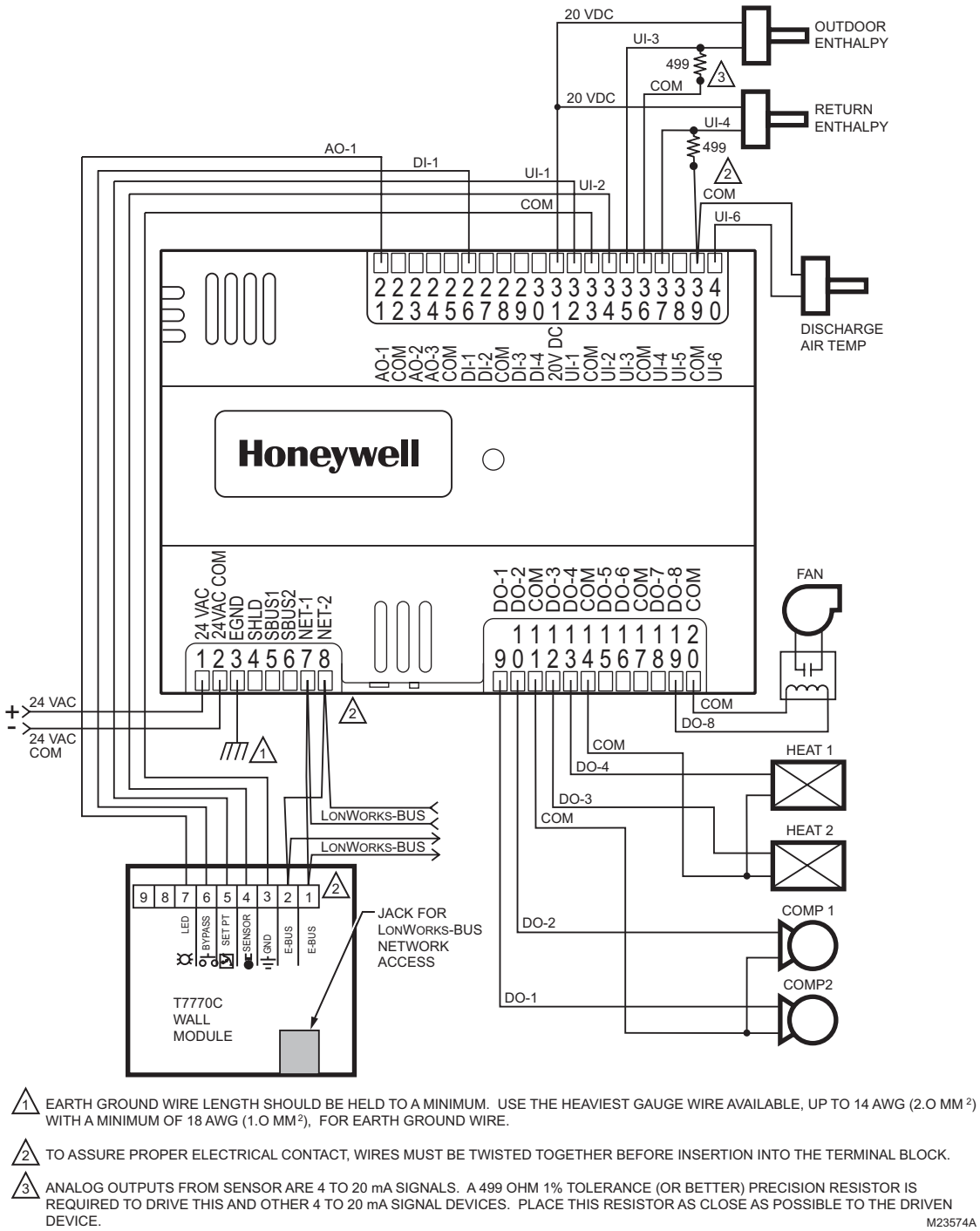
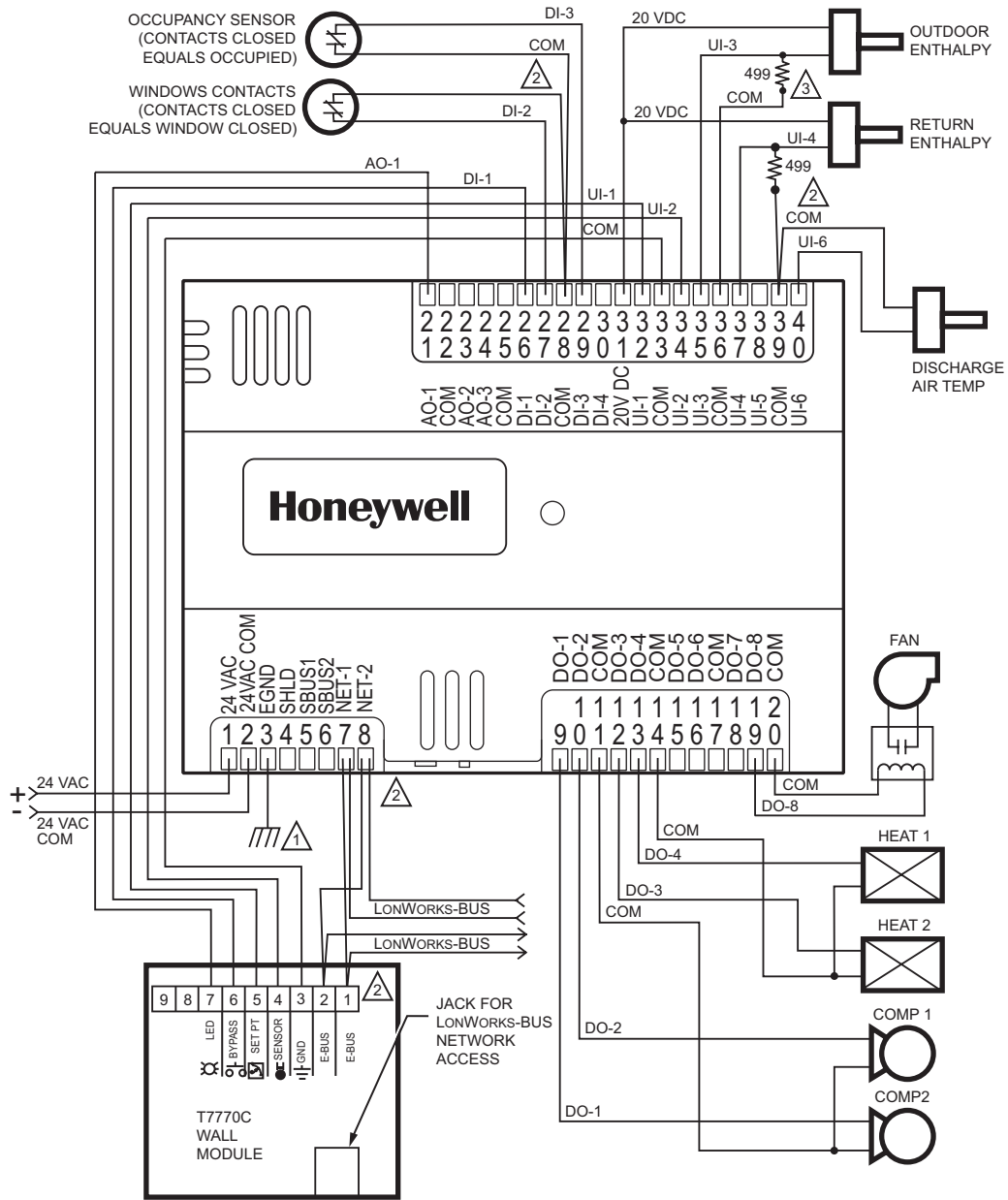
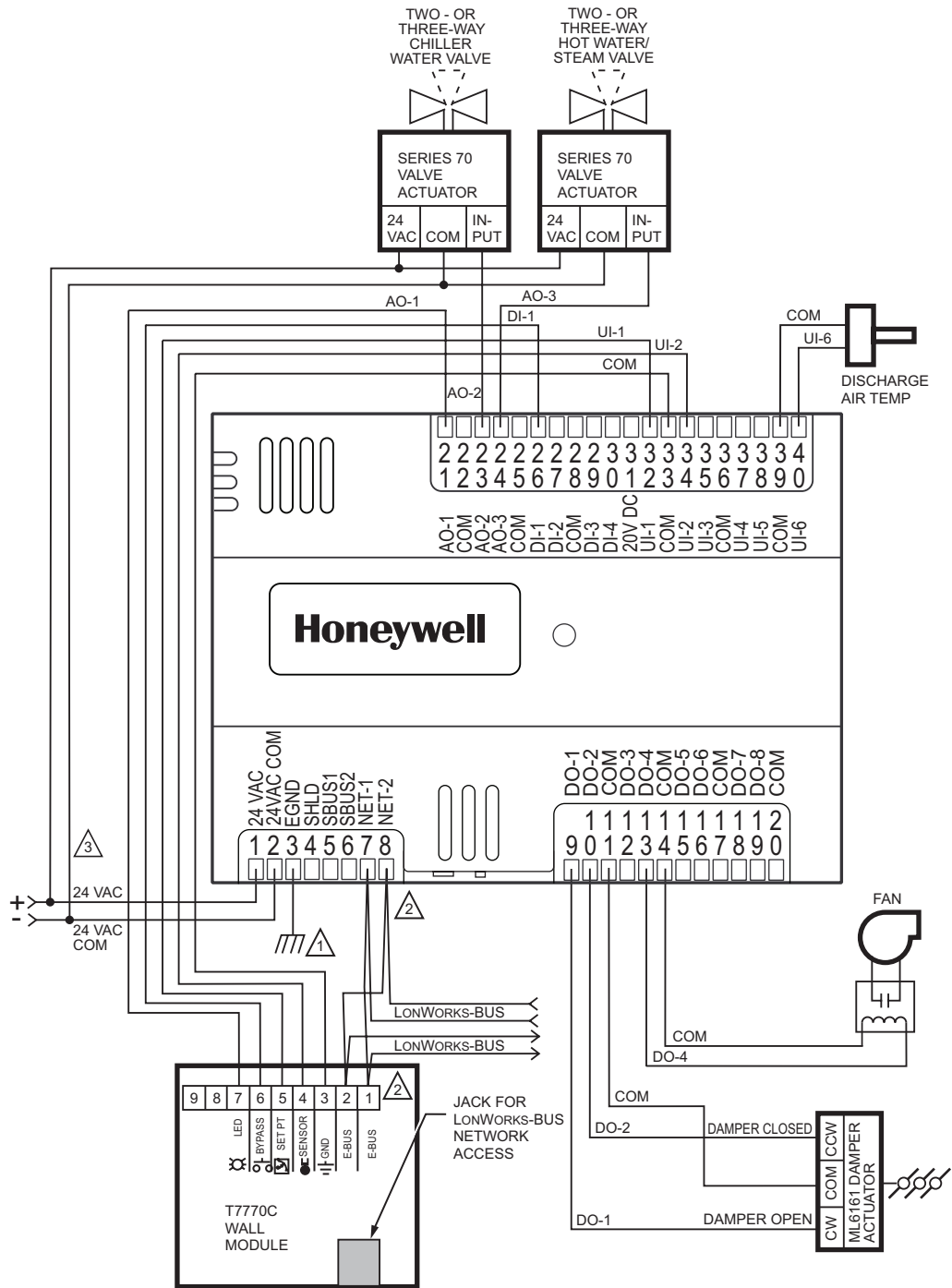

Fig. 18. Controller wiring diagram (model PUL6438S shown) for typical AHU application. (For note 2, refer to Fig. 13.)



- 1 EARTH GROUND WIRE LENGTH SHOULD BE HELD TO A MINIMUM. USE THE HEAVIEST GAUGE WIRE AVAILABLE, UP TO 14 AWG (2.0 MM²) WITH A MINIMUM OF 18 AWG (1.0 MM²), FOR EARTH GROUND WIRE.
- 2 TO ASSURE PROPER ELECTRICAL CONTACT, WIRES MUST BE TWISTED TOGETHER BEFORE INSERTION INTO THE TERMINAL BLOCK.
- 3 ANALOG OUTPUTS FROM SENSOR ARE 4 TO 20 mA SIGNALS. A 499 OHM 1% TOLERANCE (OR BETTER) PRECISION RESISTOR IS REQUIRED TO DRIVE THIS AND OTHER 4 TO 20 mA SIGNAL DEVICES. PLACE THIS RESISTOR AS CLOSE AS POSSIBLE TO THE DRIVEN DEVICE. M23575A

Fig. 19. Controller wiring diagram (model PUL6438S shown) with 4 to 20 mA enthalpy sensors and digital inputs. (For note 2, refer to Fig. 13.)



- ⚠️ 1 EARTH GROUND WIRE LENGTH SHOULD BE HELD TO A MINIMUM. USE THE HEAVIEST GAUGE WIRE AVAILABLE, UP TO 14 AWG (2.0 MM²) WITH A MINIMUM OF 18 AWG (1.0 MM²), FOR EARTH GROUND WIRE.
- ⚠️ 2 TO ASSURE PROPER ELECTRICAL CONTACT, WIRES MUST BE TWISTED TOGETHER BEFORE INSERTION INTO THE TERMINAL BLOCK.
- ⚠️ 3 MAKE SURE ALL TRANSFORMER/POWER WIRING IS AS SHOWN: REVERSING TERMINATIONS WILL RESULT IN EQUIPMENT MALFUNCTION.

M23576A

Fig. 20. Controller wiring diagram (model PUL6438S shown) with 4 to 20 mA heating, cooling, and model ML6161 damper actuator. (For note 2, refer to Fig. 13.)

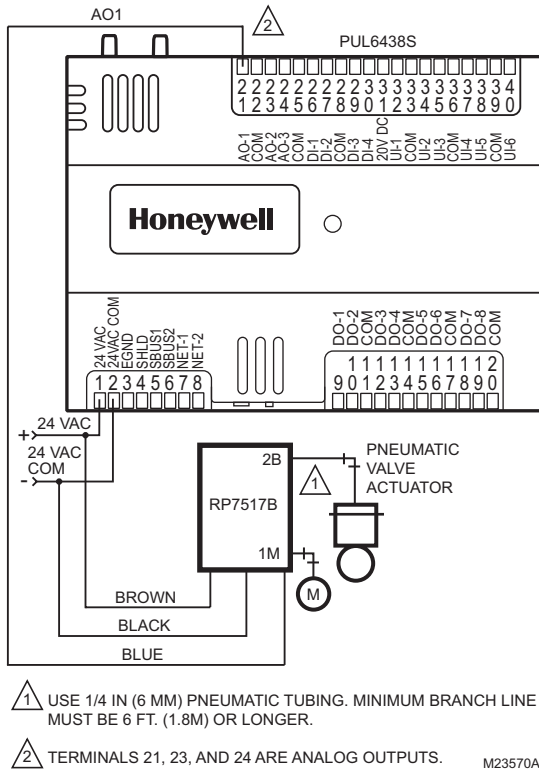

Fig. 21. Controller wiring diagram (model PUL6438S shown) for RP7517B pneumatic transducer.

CHECKOUT

Step 1. Check Installation and Wiring

Inspect all wiring connections at the controller terminals, and verify compliance with installation wiring diagrams. If any wiring changes are required, *first* be sure to remove power from the controller *before* starting work. Pay particular attention to:

- 24 Vac power connections. Verify that multiple controllers being powered by the same transformer are wired with the transformer secondary connected to the same input terminal numbers on each controller. Use a meter to measure 24 Vac at the appropriate terminals. See Fig. 11 on page 10. (Controller configurations are not necessarily limited to three devices, but the total power draw, including accessories, cannot exceed 100 VA when powered by the same transformer (U.S. only).
- Be sure that each controller has terminal 3 wired to a verified earth ground, using a wire run as short as possible with the heaviest gauge wire available, up to 14 AWG (2.0 sq mm) with a minimum of 18 AWG (1.0 sq mm) for each controller in the group. See Fig. 11 on page 10.
- Verify that Triac wiring of the digital outputs to external devices use the proper load power and 24 Vac common terminal (terminals 11, 14, 17, and 20) for High-Side switching.

NOTE: All wiring must comply with applicable electrical codes and ordinances or as specified on installation wiring diagrams.

For guidelines for wiring run lengths and power budget, see “Power” on page 7.

VERIFY TERMINATION MODULE PLACEMENT (MULTIPLE CONTROLLERS ONLY)

The installation wiring diagrams should indicate the locations for placement of the 209541B Termination Module(s). See Fig. 12 on page 12 and refer to the “LONWORKS® Bus Wiring Guidelines,” form 74-2865, and the “Excel 10 FTT Termination Module Installation Instructions,” form 95-7554.

Correct placement of the termination module(s) are required for proper LONWORKS® Bus communications.

Step 2. Startup

Refer to Fig. 22 and the following text for startup information.

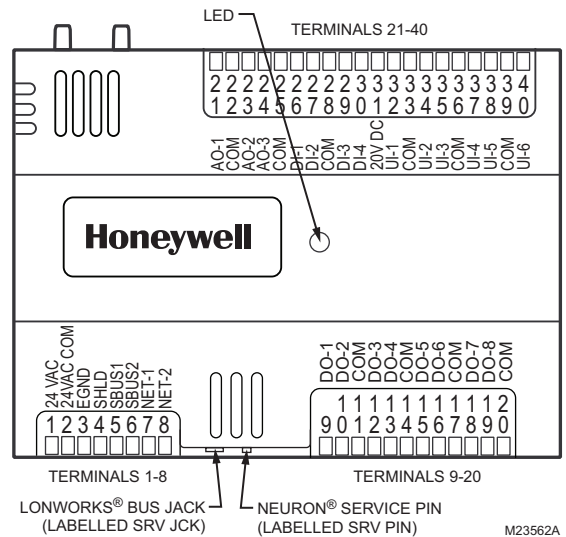

Fig. 22. LED, Service Pin, and Network connection locations.

BROADCAST THE SERVICE MESSAGE

The Service Message allows a device on the LONWORKS® Bus to be positively identified. The Service Message contains the controller’s Neuron® ID number and node type. This is used to confirm the physical location of a particular Excel 10 device in a building.

- To send the Service Message from the controller, press the NEURON® Service Pin pushbutton on the controller (see Fig. 22). This button sends out the Service Message when it is pressed, regardless of the controller’s current mode of operation.

CAUTION

Equipment Damage Hazard.

Can cause controller damage or failure.

Do not use any metal object to press the NEURON® Service Pin. Use a plastic rod or wood device (such as a pencil with the lead broken off) to press the pin. Using a metal object can damage the circuitry of the controller.

CONTROLLER STATUS LED:

The LED on the front of the controller provides a visual indication of the status of the device. When the controller receives power, the LED appears in one of the following allowable states, as described in Table 7

Table 7. Status LED States.

LED State	Blink Rate	Status or Condition
OFF	not applicable	No power to processor, LED damaged, low voltage to board, or controller damaged.
ON	ON steady; not blinking	Processor and/or controller is not operating.
Very Slow Blink (continuous)	1 second ON, 1 second OFF	Controller is operating normally.
Slow Blink (continuous)	0.5 second ON, 0.5 second OFF	Controller alarm is active, controller in process of download, or controller lost its configuration.
Medium Blink (continuous)	0.25 second ON, 0.25 second OFF	Controller firmware is loading.
Fast Blink (continuous)	0.10 second ON, 0.10 second OFF	Controller is in manual mode under control of the PC-based software tool.

Step 3. Checkout Completion

At this point the controller is installed and powered. To complete the checkout, the NIAGARA FRAMEWORK® application (run on a PC) is used to configure the I/O and functions of the controller. Refer to the Programming Tool User Guide, form no. 74-4042, for controller configuration and programming details.

CONTROLLER REPLACEMENT

There are no serviceable or repairable parts inside the controller.

⚠ WARNING

Fire, Explosion, or Electrical Shock Hazard.
Can cause severe injury, death or property damage.
 Do not attempt to modify the physical or electrical characteristics of this device in any way. Replace it if troubleshooting indicates a malfunction.

⚠ WARNING

Electrical Shock Hazard.
Can cause severe injury, death or property damage.

Disconnect power supply before beginning controller replacement to prevent electrical shock or equipment damage.

Terminal Block Removal

To simplify controller replacement, all terminal blocks are designed to be removed with the wiring connections intact and then re-installed on the new controller. See Fig. 23 and refer to the following procedure:

IMPORTANT

To prevent bending or breaking the alignment pins on longer terminal blocks, insert the screwdriver at several points to evenly and gradually lift up the terminal block.

Insert the screwdriver blade no more than 1/8 in. (3 mm) to prevent damage to the terminal block alignment pins on the controller circuit board.

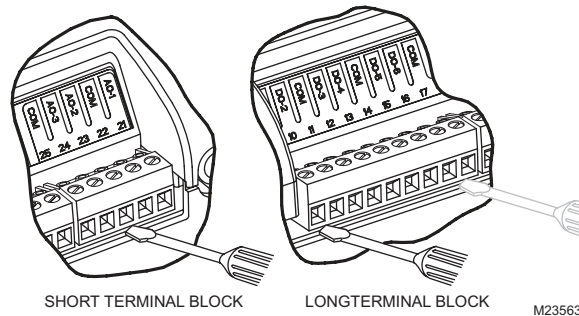

Fig. 23. Removing Terminal Blocks.

1. Use a thin-bladed screwdriver to evenly raise the terminal block from its alignment pins:
 - a. For short terminal blocks (1 to 5 terminals), insert screwdriver blade in center of terminal block and use a back and forth twisting motion to gently raise the terminal block from its alignment pins 1/4 in. (6.35 mm).
 - b. For long terminal blocks (6 or more terminals), insert screwdriver blade on one side of the terminal block and gently rotate the blade 1/4 turn. Then, move to the other side of the terminal block and do the same. Repeat until the terminal block is evenly raised 1/4 in. (6.35 mm) from its alignment pins.
2. Once the terminal block is raised 1/4 in. (6.35 mm) from its alignment pins, grasp the terminal block at its center (for long terminal blocks grasp it at each end) and pull it straight up.

Controller Replacement (PVL6436AS only)

For PVL6436AS controllers, which are hard-wired to an actuator, perform the following to replace the complete assembly (controller and actuator):

1. Remove all power from the controller.
2. Remove the two air flow pickup connections from the pressure sensor.
3. Remove the terminal blocks.
 - See “Terminal Block Removal” on page 22.
4. Remove the old controller and actuator assembly from its mounting.
 - Loosen the two bolts on the actuator clamp to release the actuator from the shaft.
 - Remove the controller’s mounting screws.
 - Gently pull the controller and actuator assembly straight out, until the assembly is clear of the actuator shaft.
5. Mount the new controller and actuator assembly.
 - See “Installation” on page 3.
6. Reconnect the two air flow pickup tubes to the pressure sensor.
 - See “Piping (PVL6436AS and PVL6438NS only)” on page 6.
7. Replace the terminal blocks:
 - Insert each terminal block onto its alignment pins.
 - Press straight down to firmly seat it.
 - Repeat for each terminal block.
8. Restore power to the controller.
9. Perform “Checkout” on page 21.

Controller Replacement (PVL6438NS only)

Perform the following to replace the PVL6438NS controller:

1. Remove all power from the controller.
2. Remove the two air flow pickup connections from the pressure sensor.
3. Remove the terminal blocks.
 - See “Terminal Block Removal” on page 22.
4. Remove the old controller from its mounting.

IMPORTANT

(FOR CONTROLLERS MOUNTED TO A DIN RAIL):

1. Push straight up from the bottom to release the top pins.
2. Rotate the top of the controller outwards to release the bottom flex connectors (see Fig. 6 on page 6).
5. Mount the new controller.
 - See “Installation” on page 3.
6. Reconnect the two air flow pickup tubes to the pressure sensor.
 - See “Piping (PVL6436AS and PVL6438NS only)” on page 6.
7. Replace the terminal blocks:
 - Insert each terminal block onto its alignment pins.
 - Press straight down to firmly seat it.
 - Repeat for each terminal block.
8. Restore power to the controller.
9. Perform “Checkout” on page 21.

Controller Replacement (PUL6438S only)

Perform the following to replace the PUL6438S controller:

1. Remove all power from the controller.
2. Remove the terminal blocks.
 - See “Terminal Block Removal” on page 22.
3. Remove the old controller from its mounting.

IMPORTANT

(FOR CONTROLLERS MOUNTED TO A DIN RAIL):

1. Push straight up from the bottom to release the top pins.
2. Rotate the top of the controller outwards to release the bottom flex connectors (see Fig. 6 on page 6).
4. Mount the new controller.
 - See “Installation” on page 3.
5. Replace the terminal blocks:
 - Insert each terminal block onto its alignment pins.
 - Press straight down to firmly seat it.
 - Repeat for each terminal block.
6. Restore power to the controller.
7. Perform “Checkout” on page 21.

LON®, LONTALK®, LONWORKS® and NEURON® are registered trademarks of Echelon® Corporation.

LONMARK® and the LonMark Logo are trademarks of the LonMark Association.

NIAGARA FRAMEWORK® and the Niagara framework logo are registered trademarks of Tridium, Inc.

Automation and Control Solutions

Honeywell International Inc.
1985 Douglas Drive North
Golden Valley, MN 55422
customer.honeywell.com

Honeywell Limited-Honeywell Limitée
35 Dynamic Drive
Toronto, Ontario M1V 4Z9

